

NATIONAL ADVISORY COMMITTEE FOR AERONAUTICS

# WARTIME REPORT

ORIGINALLY ISSUED

May 1945 as  
Memorandum Report E5E08

TESTS OF AIR VALVES FOR INTERMITTENT-JET ENGINES

AT SPEEDS OF 20 AND 25 CYCLES PER SECOND

By Joseph R. Bressman and Robert J. McCready

Aircraft Engine Research Laboratory  
Cleveland, Ohio

JPL LIBRARY  
CALIFORNIA INSTITUTE OF TECHNOLOGY

COPY FILE

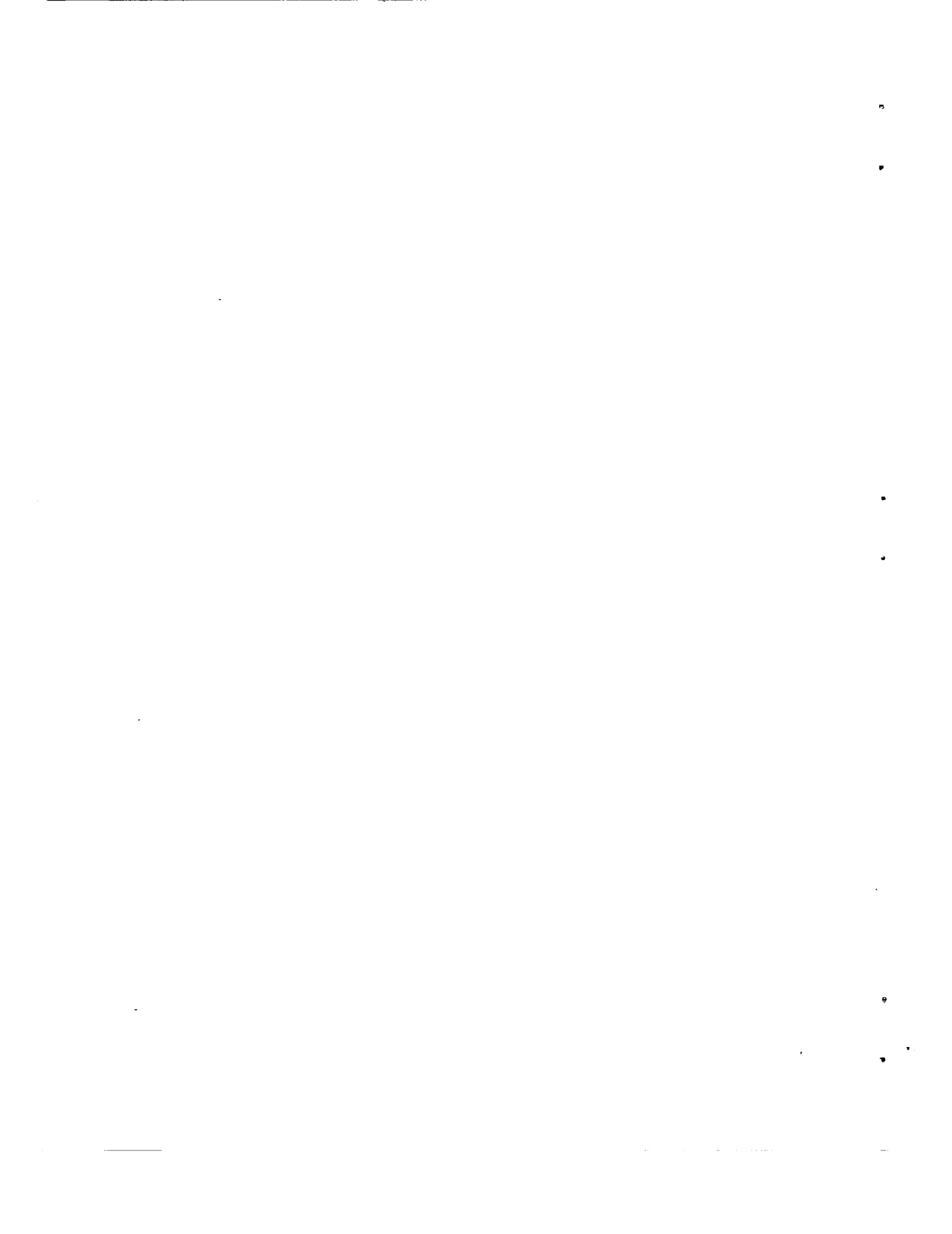


WASHINGTON

NACA WARTIME REPORTS are reprints of papers originally issued to provide rapid distribution of advance research results to an authorized group requiring them for the war effort. They were previously held under a security status but are now unclassified. Some of these reports were not technically edited. All have been reproduced without change in order to expedite general distribution.

MAY 17 1948

E-258



NATIONAL ADVISORY COMMITTEE FOR AERONAUTICS

MEMORANDUM REPORT

for the

Bureau of Aeronautics, Navy Department

TESTS OF AIR VALVES FOR INTERMITTENT-JET ENGINES

AT SPEEDS OF 20 AND 25 CYCLES PER SECOND

By Joseph R. Bressman and Robert J. McCready

SUMMARY

A study of automatic nonreturn air valves for use in an intermittent-jet engine has been made. A test apparatus that simulates the cycle pressure variations in an intermittent-jet engine was devised and five types of valve were tested in this apparatus at speeds of 20 and 25 cycles per second. Four valve-spring and three valve-grill materials were used. Blue spring steel was the best valve-spring material tried and aluminum the best grill material. Altering the contour of the valve support structure or grill, with the result that the valve spring in the normal position was arched rather than fitted to the grill along its length, improved the life of the valve. The results of these tests are preliminary in nature, inasmuch as the speeds of present application are higher than those of this series of tests and relative in that the effect of various factors was determined.

INTRODUCTION

An analysis of the characteristics of the German robot-bomb intermittent-jet engine indicates the effect of proper valve design on the over-all performance of the unit. The German air valve utilizes a large percentage of the available cross-sectional area for valve-support structure and requires relatively high pressure differentials for full opening. The life is approximately 30 minutes under actual operating conditions. Limitation of the free-flow area reduces the amount of air charged into the combustion chamber during the intake part of the cycle. High pressure differentials between the combustion chamber and the free stream cause excessive power losses because of a reversal of flow in the tail pipe and low charge-air densities in the combustion chamber. A life expectancy of 30 minutes limits the range of such a missile.

At the request of the Bureau of Aeronautics, Navy Department, a study of automatic nonreturn air valves for use in an intermittent-jet engine has been made at the NACA Cleveland laboratory. The valve investigations reported herein concentrated primarily on small cross-sectional support area, low pressure-drop valve springs, and length of life. Relatively large grills (as compared with the German-type valve) were chosen because the valve-support structure would be a smaller percentage of the available cross-sectional area. Relatively large valves of thicknesses of the order of the German-type valve can be designed for low stiffness in order to reduce the pressure differentials necessary for full opening of the valve; a maximum life, consistent with low losses, was sought.

Five types of valve were tested at speeds of 20 and 25 cycles per second. Four valve-spring and three valve-grill materials were used.

#### DESCRIPTION OF VALVES

A small cross section of the German-type valve (fig. 1) was prepared in order that the steady-flow pressure drop of this valve could be compared with the valves of NACA design. No cyclic tests on this valve were conducted in the series of tests reported herein.

Tests at 20 cycles per second were conducted on valve A (fig. 2), which is approximately five times as large as the German-type valve. The contour of this valve is an arc of  $4\frac{5}{8}$ -inch radius. The valve spring was made of thicknesses of 0.008, 0.010, 0.012, and 0.015 inch blue spring steel and was fastened to the grill with the aid of a support plate, as shown in figure 2(a). Most of the tests were performed with blue spring steel because this material has excellent spring properties and a high endurance limit. The average composition determined by a metallurgical examination is given in the following table:

Composition	Percentage
Nickel	0.10-0.33
Molybdenum	.03- .12
Silicon	.15- .30
Manganese	.75-2.50
Chromium	.40- .50
Carbon	.80-1.20
Iron	Remainder

The physical properties of blue spring steel for various thicknesses are presented in the following table:

Thickness (in.)	Direction of testing	Tensile strength (lb/sq in.)	Yield strength (lb/sq in.)	Percentage elongation (2-in. gage length)
0.008	P <sup>1</sup>	285,000	272,200	3
.011	P	264,700	242,700	7
.011	T <sup>2</sup>	263,500	240,000	4
.012	P	239,900	223,800	5
.012	T	216,300	210,500	-----

<sup>1</sup> Parallel to direction of rolling.

<sup>2</sup> Transverse to direction of rolling.

When samples of blue spring steel were examined under a microscope, the material showed inclusions of foreign substances arranged in bands parallel to the direction of rolling. Examination of valve failures indicated, in some instances, fine cracks starting at or running through an inclusion in the steel.

Tests at 25 cycles per second were conducted on valves B, C, D, and E. Valve B (fig. 3) is composed of two valves operating as a unit, each of which is a scale model of valve A. The cross-sectional area of valve B is approximately the same as valve A. The springs for valve B were made of blue spring steel, low-carbon shim steel, spring brass, and spring bronze. Flat, curved, and rubber-tipped support plates (figs. 3(a), 6(b), and 6(c)), respectively, were used in the tests of valve B. Valve C (fig. 4) and valve D (fig. 5) are the same type as valve B with the exception that the grill-contour radius was changed to a 4-inch and 5-inch radius, respectively. The valve spring was the same as that of valve B and in all cases had a 3-inch radius. Valve E is of the same type as valve B with the exception that the trailing edge of the grill was rounded off instead of coming to a point as in valve B. Photographs of valves A, B, D, and E are presented in figure 6.

#### TEST APPARATUS

Cyclic-test apparatus. - The apparatus designed to test a small section of a complete valve assembly for an intermittent-jet engine is shown in figure 7. A commercial nine-cylinder radial engine was set up with all of the cylinders removed except the one containing

the master rod and piston. This cylinder was then replaced by a cylinder barrel on which the test chamber was mounted. The valve section was mounted on the intake side of the chamber and the exhaust side was connected to the laboratory altitude exhaust. A variable-speed dynamometer supplied the power to drive the engine. The air flow through the valve induced by the altitude exhaust simulated ram velocity of an engine in flight. The rapid rise in pressure due to combustion was approximated by the pressure rise resulting from the up stroke of the piston. The suction created by the rush of hot gases out the tail pipe in an engine was simulated by the pressure drop caused by the down stroke.

Frequency of the cycle was varied by changing the speed of the dynamometer. Test-chamber pressures were controlled by means of the butterfly valve and the altitude-exhaust pressures. At a constant cycle frequency, when the butterfly valve was closed or the air flow induced by the altitude exhaust was reduced by increasing pressures downstream of the test chamber with the aid of the altitude-exhaust control valve, peak chamber pressures could be increased with only a slight increase in the minimum pressure. When the butterfly valve was opened or the mass flow was increased by lowering the downstream pressures, peak and minimum chamber pressures could be lowered. In general, the minimum chamber pressure was less sensitive to control than the peak pressure.

Steady-flow apparatus. - Losses in total pressure with a steady air flow were determined with the aid of the apparatus shown in figure 8. The valve section was fastened to a transition piece that changed from a rectangular cross section to that of a circular pipe. This pipe was connected to an orifice and then to the altitude exhaust. A static-ring and a total-pressure tube were placed sufficiently far downstream to permit the flow pattern to stabilize. A total-pressure survey was taken in a vertical plane and the loss in total pressure was averaged over the area of the pipe. Because the Reynolds number at the total-pressure tube was of the order of 200,000, the total pressure averaged over the area was assumed to be approximately equal to the total pressure averaged over the mass flow. The entrance and the friction losses in the system were determined at various mass flows without the valves. These values were then deducted from the gross loss determined with the valves.

The static-pressure-ring and the orifice readings were used as a check on the total-pressure tube survey. The orifice measured the mass flow and the density at the test station was determined by the static pressure. The mean velocity and the velocity pressure at the test station was then computed. From the velocity pressure,

the total-pressure loss averaged over the area was checked. Deviations in the values of loss calculated by the two methods averaged approximately 1 percent.

Apparatus for determining natural frequency of the valves. - The natural frequency of the valves was determined by an electromagnet connected with an audio-oscillator. The spring-steel valve was clamped in a vise at the same point at which it is fastened in an actual test installation. The electromagnet was brought close to the valve and the frequency of the alternating current was varied by the audio-oscillator until the valve was set into sympathetic vibrations. The lowest frequency at which this vibration occurred is called the natural frequency of the valve.

The natural frequency of a valve is an indication of its stiffness, which in turn controls the steady-flow pressure loss and the pressure differential required to open the valve. The higher the natural frequency of a valve the stiffer it will be; consequently, a greater pressure differential is necessary to open the valve fully. The steady-flow total-pressure loss will also be larger if the valve does not open fully.

Instrumentation for cyclic-test apparatus. - Pressure fluctuations in the chamber downstream of the valve were measured by a piezoelectric crystal pressure pickup and were recorded as vertical deflections on an oscilloscope. The pressure-pickup characteristics were calibrated by a balanced-pressure diaphragm pickup that permitted the determination of the absolute value of the maximum pressure in the cycle. The horizontal sweep on the oscilloscope was obtained by an angular-sweep potentiometer that was rigidly connected to turn with the engine shaft and maintained a substantially linear relation between the sweep and the engine crank angle. Thus, the relation of pressure to crank angle and, therefore time (inasmuch as the cycle frequency is known), was determined. An averaged pressure for the cycle for use in checking the pressure pickup data and in resetting test conditions was obtained by means of a static-pressure tap and a collector tank.

Valve motion was observed by means of a stroboscope that was controlled by an electric contactor. The contactor was geared to the engine shaft and by shifting the position of the commutator brushes, a flash on the stroboscope could be achieved at any crank angle desired. In this manner, the relation of valve position with crank angle, and therefore time, was found. By means of the pressure-time and valve-position-time records the valve movement was related to the pressure fluctuations.

The mean mass flow was measured by an orifice far enough downstream from the pressure chamber to make the static-pressure readings fairly constant.

Cycle frequency was determined by measuring the rotative speed of the engine with the aid of a chronometric tachometer consisting of a standard aircraft electric tachometer and a combination revolution counter-timer.

## RESULTS AND DISCUSSION

Valve failures were classified as either fraying or flexing failures (splits). A fraying failure is characterized by small saw-tooth cuts where chips of metal have been broken out at the tip or trailing edge of the valve (fig. 9(a)). A flexing failure occurs back from the tip and is characterized by a split in the material along the line of bending (fig. 9(b)). Occasionally large pieces of valve material flow out when failure started as a flex split. A valve was considered to have failed when the first signs of fraying or splitting were noted. In most of the cases, a valve considered a fraying failure still sealed and might have continued to operate satisfactorily for some time. In order to establish a uniform standard of testing, the time at which initial failure occurred was considered as the criterion of useful life.

### Tests at 20 Cycles per Second

All tests at 20 cycles per second were conducted on type A valves. When a flat valve approximately 0.005 inch thick was tested with a steady flow of air, the valve had a tendency to flutter. By means of a stroboscope, the valve was observed to take a curved shape on reaching the full-open position and to form a venturi section. The low pressures in the venturi tended to pull the valve down. The air stream lifted the valve again and the process repeated itself, which resulted in fluttering. In order to eliminate this action, a circular valve was designed to straighten out into a plane when fully open instead of taking a curved shape. The result is that the contour of valve A (fig. 2(a)) is an arc of single radius.

Steady-flow losses. - Steady-flow losses are shown in figure 10 for three type A valves of various thicknesses. Valve A is considered a "soft" valve (as opposed to "stiff" in describing the German-type valve) and has a low total-pressure loss.

The effect of grill material. - The following results were obtained from tests on steel, aluminum, and bakelite grills in order to demonstrate the effect of grill material on valve life:



Grill material	Life (min)
Steel	20
Bakelite	53
Aluminum	Over 100

Inserts of bakelite and of rubber 1/8 inch thick were placed in the trailing edge of the steel grill to prevent fraying. Tests of 0.012-inch-thick valves showed a life of 69 minutes without the rubber insert and 79 minutes with the insert. No noticeable increase in life was noted with the bakelite insert.

The effect of upper-plate material. - In the course of the cyclic tests, it was found that type A valves frayed as they hit the upper support plate when opened (fig. 2(a)). For this reason, it is probable that inserts in the grill did not result in any remarkable improvement in valve life. A rubber strip was cemented to the upper support plate to absorb the impact when the valve opened and increase the valve life. Tests with an 0.012-inch-thick valve and steel grill resulted in 36 minutes of life with a steel support plate and in excess of 79 minutes with a rubber-covered upper support plate. An aluminum plate was more satisfactory than the steel plate but not so good as the rubber-covered plate. Undoubtedly, the ordinary rubber used in these tests would be unsatisfactory for use in an actual unit, but a high-temperature silicon rubber or plastic might be used in its place.

An attempt was also made to absorb the impact when the valve opened by means of a piece of spring steel bent to form a support-plate spring, as shown in figure 2(c). The life was only several minutes.

The effect of valve thickness. - An aluminum grill tested with a rubber-covered upper plate showed a variation of valve life with valve thickness as follows:

Thickness (in.)	Valve life (min)
0.015	Over 100
.012	Over 100
.010	14
.008	11

The effect of valve material. - The trailing edge of a valve was annealed to a depth of 3/4 inch, from a Rockwell hardness of C-55 to C-30. No increase in life was noted. Failure occurred at the junction of the annealed and the unannealed section as well as at the tip. In an attempt to absorb the impact stresses with a softer material, a strip of low-carbon shim steel 3/8 inch wide was silver-soldered to the trailing edge of the valve to form a double thickness at the tip. This valve failed after several minutes.

Tests at higher speeds and pressures. - All the foregoing results on valves were obtained with tests in which the maximum and the minimum cycle pressures were of the order of  $\pm 2$  pounds per square inch gage. Speeds in excess of 20 cycles per second or pressures higher than  $\pm 2$  pounds per square inch gage resulted only in rapid failure. Valve A is therefore considered unsatisfactory for use in an intermittent-jet engine.

#### Tests at 25 Cycles per Second

The first tests at 25 cycles per second were conducted on valve B. The natural frequency of valve B for various thicknesses is as follows:

Thickness (in.)	Frequency (cycles/sec)
0.008	35
.010	44
.012	55

Steady-flow losses. - Steady-flow losses for valve B are shown in figure 10. In the case of the 0.008-inch thickness, the loss for valve B is almost twice that of valve A, whereas for the 0.010-inch thickness, the loss for valve B is almost three times that of valve A. The losses in valve B, however, are still far below those of the German type and consequently valve B is considered a "soft" valve. A part of a German-type valve grill assembly was prepared to fit the test section in which valve A was tested (fig. 1). Steady-flow losses for the German type valve are also shown in figure 10.

The effect of upper-plate alterations. - As in the case of valve A, it was necessary to absorb the impact caused by the valve striking the support plate when opened. Tests run with a valve of 0.010-inch thickness with flat, curved, and rubber-curved support plates resulted in the following valve lives:

Support plate	Valve life (min)
Flat aluminum (fig. 3(a))	12
Curved aluminum (fig. 6(b))	31
Rubber-tipped curved aluminum (fig. 8(c))	67

The purpose of the curved support plates was to cause the valve to flex and slow down before the tip struck.

The effect of valve material. - Various types of valve material were tested under similar conditions. The results place the materials in the following order of decreasing life: blue spring steel, low-carbon shim steel, spring brass, and spring bronze.

The effect of cycle pressure. - With maximum and minimum pressures of approximately  $\pm 2$  pounds per square inch, the life of a spring-steel valve 0.008 inch thick was 25 minutes. When higher pressures were tried, immediate valve failure occurred. The valves were subjected to fraying along the trailing edge similar to the failures noted in valve A. (See fig. 9.) A possible explanation for this rapid failure may be found in the characteristic operation of this valve. The valve appeared to have a whip-like action in closing; that is, the end of the valve near its point of fastening would follow the contour of the grill for approximately half its length, at which time there would be a tendency for the rest of the valve to snap or whip shut.

The effect of altering the grill contour. - In order to eliminate this whipping action, the grill contour was first altered as shown in figure 4 (valve C) and then cut away once again as shown in figure 5 (valve D). These alterations left the valve unsupported by grill work for most of its length in the normal position. The resulting valve action was noticeably different. The valve no longer whipped shut but tended to descend to its seat with a fixed curvature over most of its length, to hit the grill on the tip, and then to collapse and fit the grill along its length. The tip had a tendency to hit edgewise rather than flat and slide forward along the grill contour as the rest of the valve seated on the grill. Tests on valves B, C, and D of 0.010-inch thickness with pressures of 2 or 3 pounds per square inch gave the following results:

Valve	Life (min)
B	25
C	50
D	138

The relation of valve-tip position and pressure variation with engine crank angle or time for one cycle is shown in figure 11 for valve C as a representative curve. The life of this valve was 138 minutes at which time the valve failed in flexing. The pressure measurements were not accurate because vibrations from the engine were detected by the piezoelectric crystal pickup and superimposed on the pressure record on the oscilloscope. It was therefore necessary to choose an average line from an oscilloscope trace approximately 1/4 to 1/2 inch wide.

The valve opened in approximately  $45^\circ$  or 0.005 second and struck the top with a velocity of approximately 18.3 feet per second. It then rebounded until it was about half-way open, was again picked up by the air stream, opened about three-fourths of the way, and finally closed with a velocity of 13.3 feet per second. The opening and the closing striking velocities were considered to be represented by the average slope of the curve during the opening and the closing parts of the cycle. For approximately 0.0044 second after the valve tip touched the grill, the valve had not completely closed against the grill and sealed. Similarly the valve tended to unseal before the valve tip started to open.

Valve E was made by rounding off the trailing edge of a grill of the same type as valve B (fig. 6(d)). The valve-spring tip now had to bend before hitting the grill and in so doing had the opposing spring force decelerating its motion prior to hitting the grill. The tests showed that the valve would not seal completely and, therefore, were discontinued. Subsequent tests, however, indicated that it was extremely difficult to design a grill whereby an adequate spring force could be used for deceleration without resulting in a permanent deformation of the valve at the point where the radius of curvature of the grill contour changed abruptly.

#### SUMMARY OF RESULTS

Tests of five types of nonreturn air valve were conducted in a cyclic-test apparatus at speeds of 20 and 25 cycles per second to determine the effects of various changes in grill contour and grill and valve material. The following results were obtained:

1. The tests on valve A at 20 cycles per second demonstrate that of the grill materials tried, aluminum was most satisfactory, that annealing the spring steel was detrimental to the life of the valve, that there is a minimum thickness for any specified life expectancy, and that the life of the valve does not vary linearly with thickness.

2. The tests on valves B, C, and D at 25 cycles per second indicate that of the spring or valve materials tried, blue spring steel is the best and that considerable improvement in life can be attained by altering the grill contour from that of a single radius to one in which the valve in the normal position was arched over the grill (as in valve D). A valve of this type requires pressure to seal.

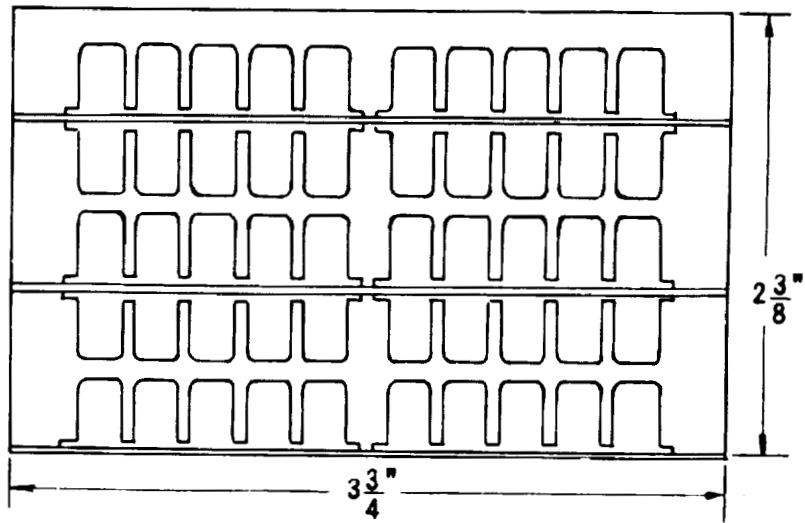
3. The results of tests on valve E were inconclusive.

Aircraft Engine Research Laboratory,  
National Advisory Committee for Aeronautics,  
Cleveland, Ohio, May 8, 1945.

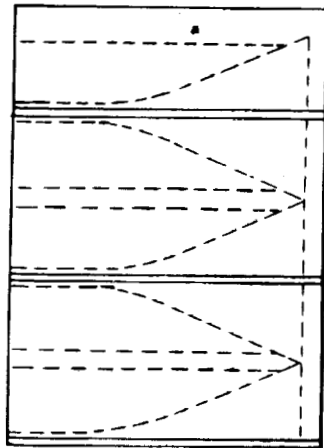
vfw



F-258

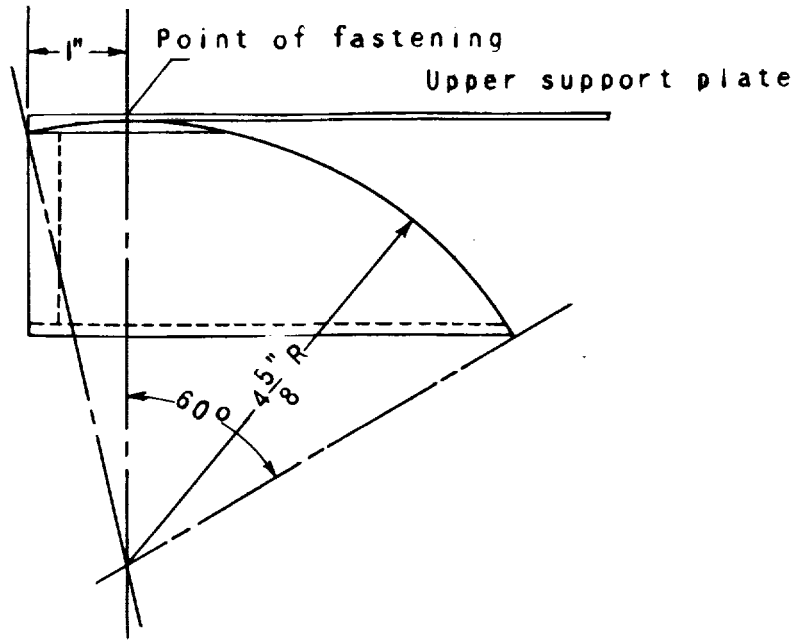


(a) Rear view.

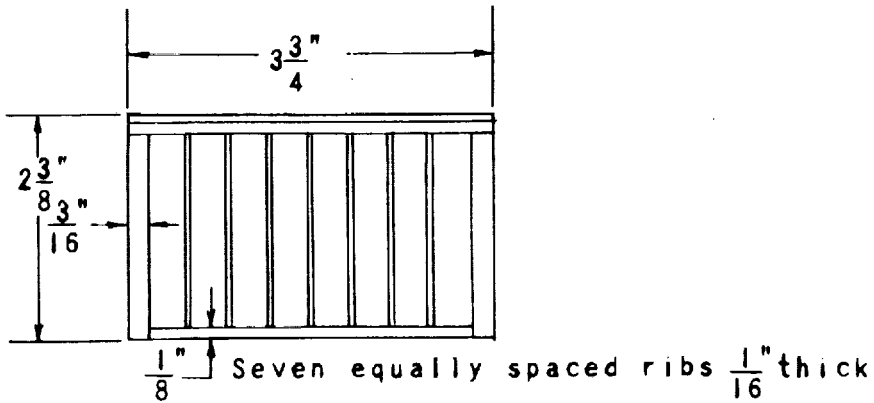


(b) Side view.

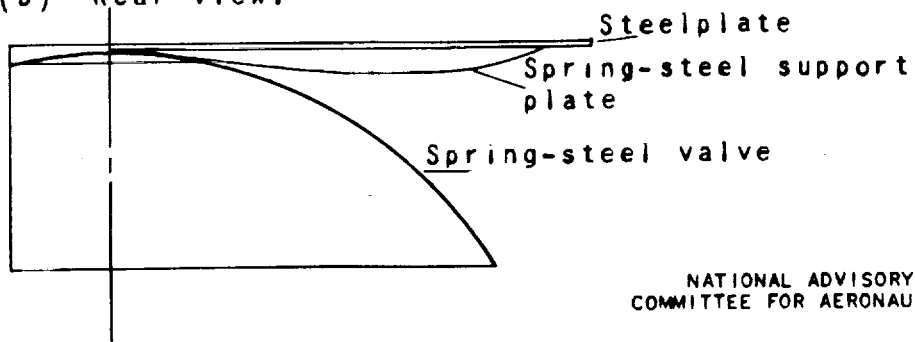
Figure 1. - Section of German-type valve used for steady-flow tests.



(a) Side view.



(b) Rear view.

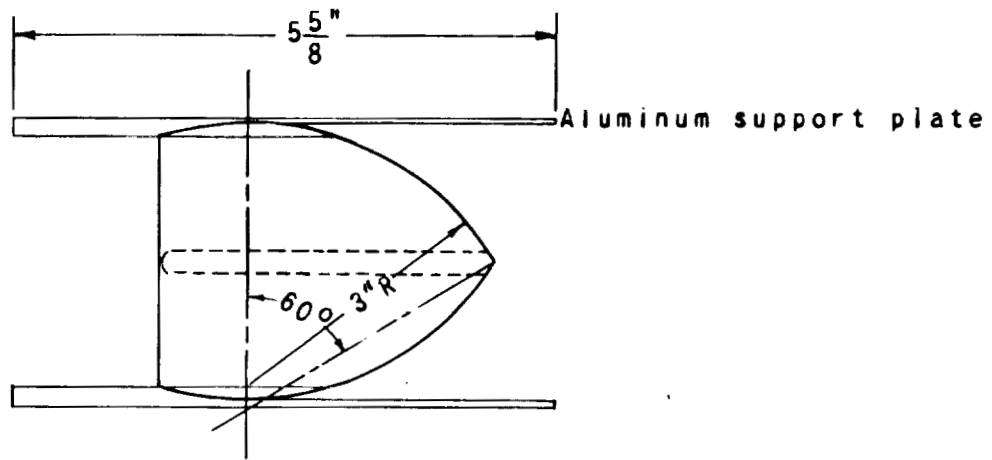


(c) Spring-steel support plate.

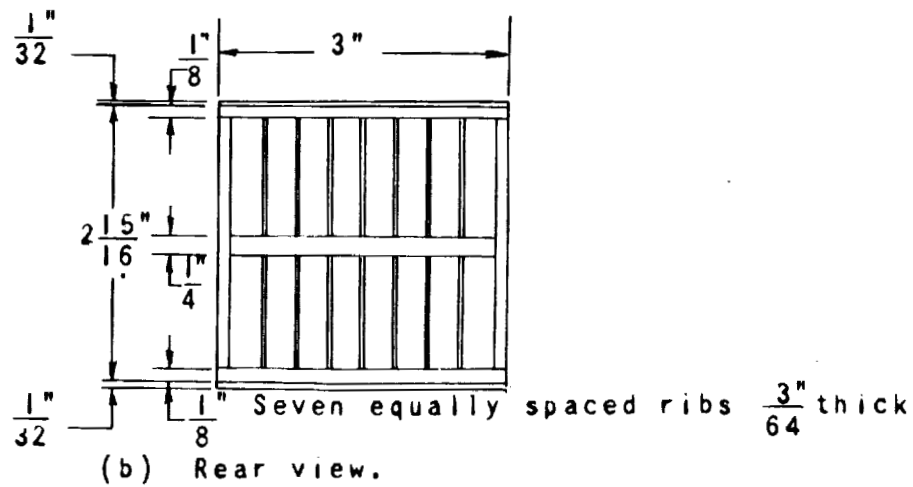
Figure 2. - Sketches of valve A.



E-258



(a) Side view.



(b) Rear view.

Figure 3. - Sketches of valve 8.

E-258

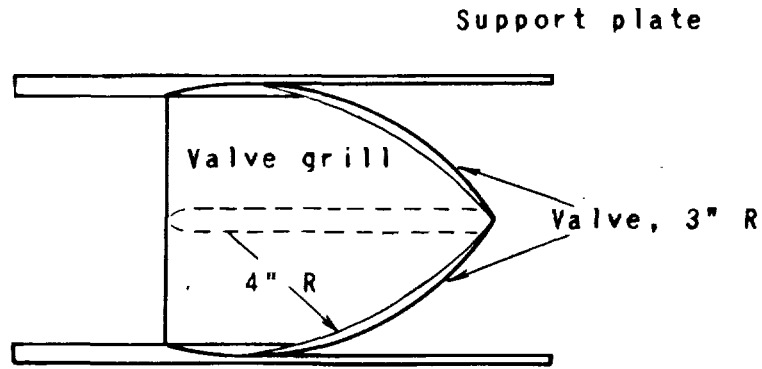


Figure 4. - Sketch of valve C.

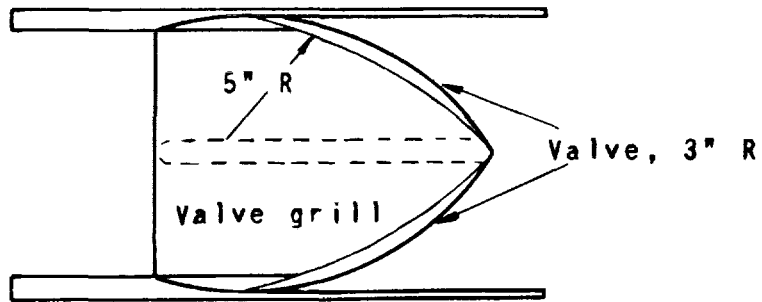
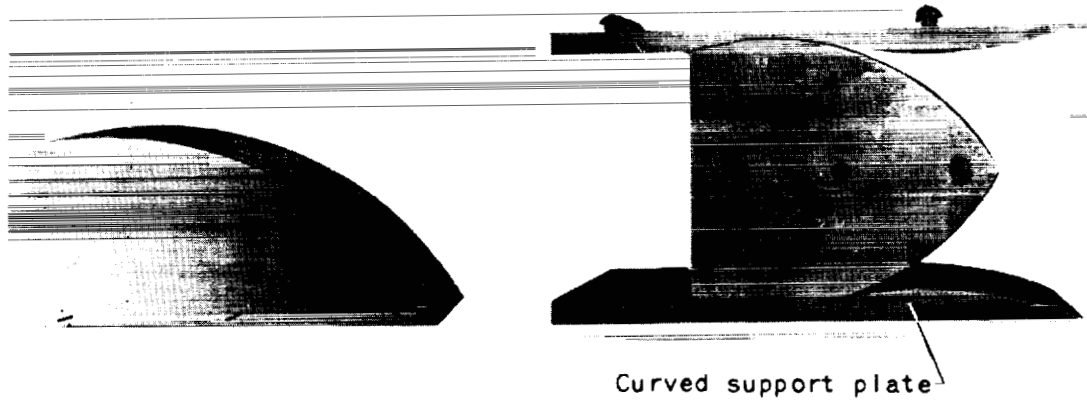


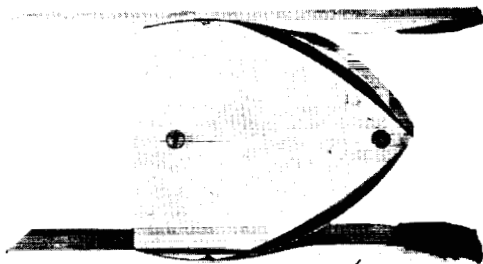
Figure 5. - Sketch of valve D.

E-258



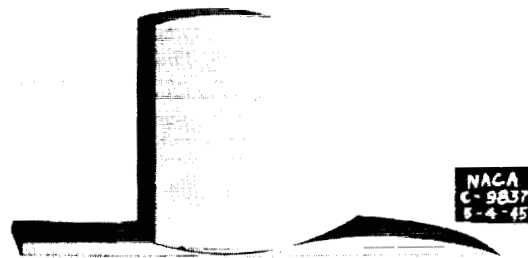
(a) Side view of valve A.

(b) Side view of valve B.



Rubber strip

(c) Side view of valve D.

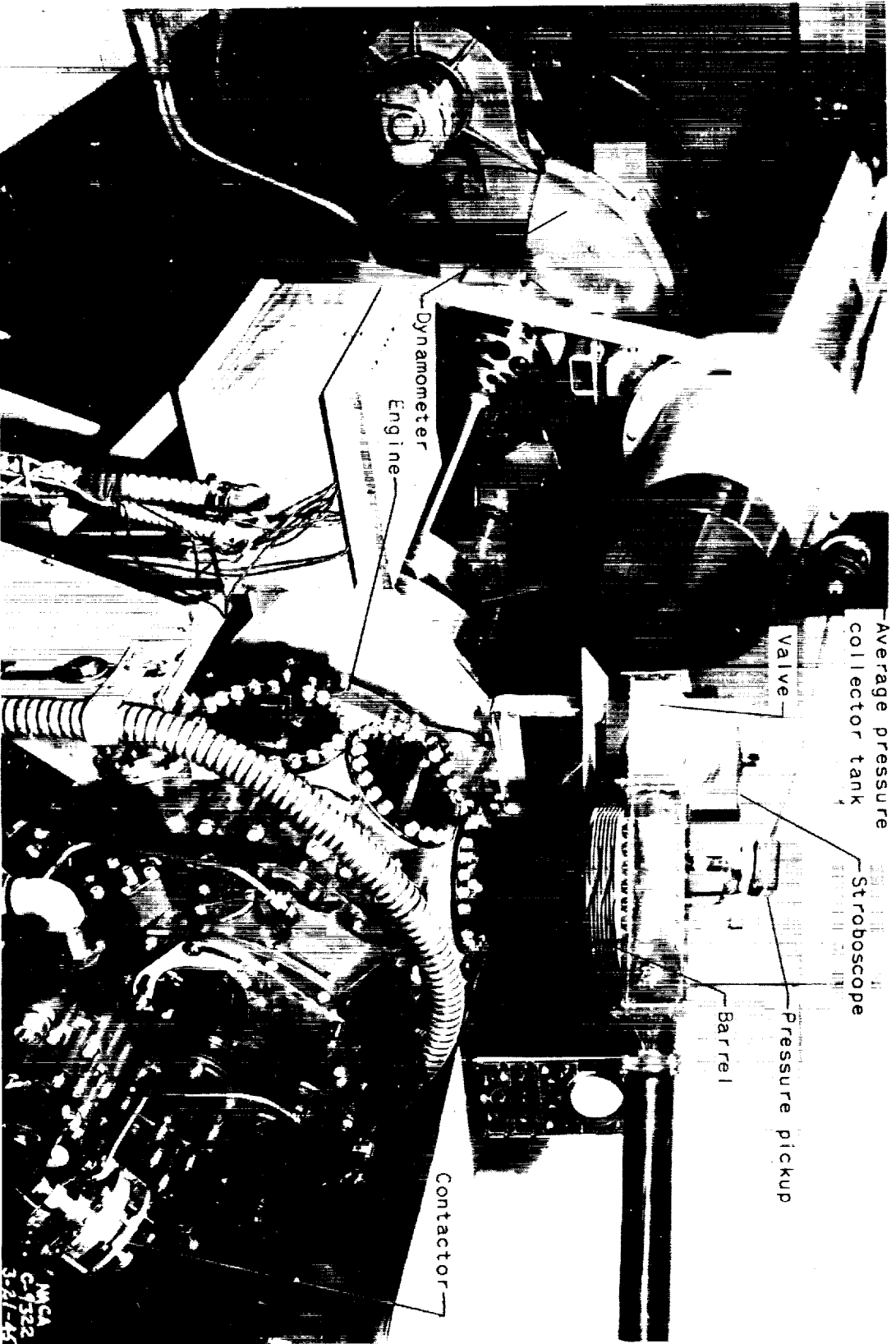


NACA  
C-9837  
8-4-45

(d) Side view of valve E.

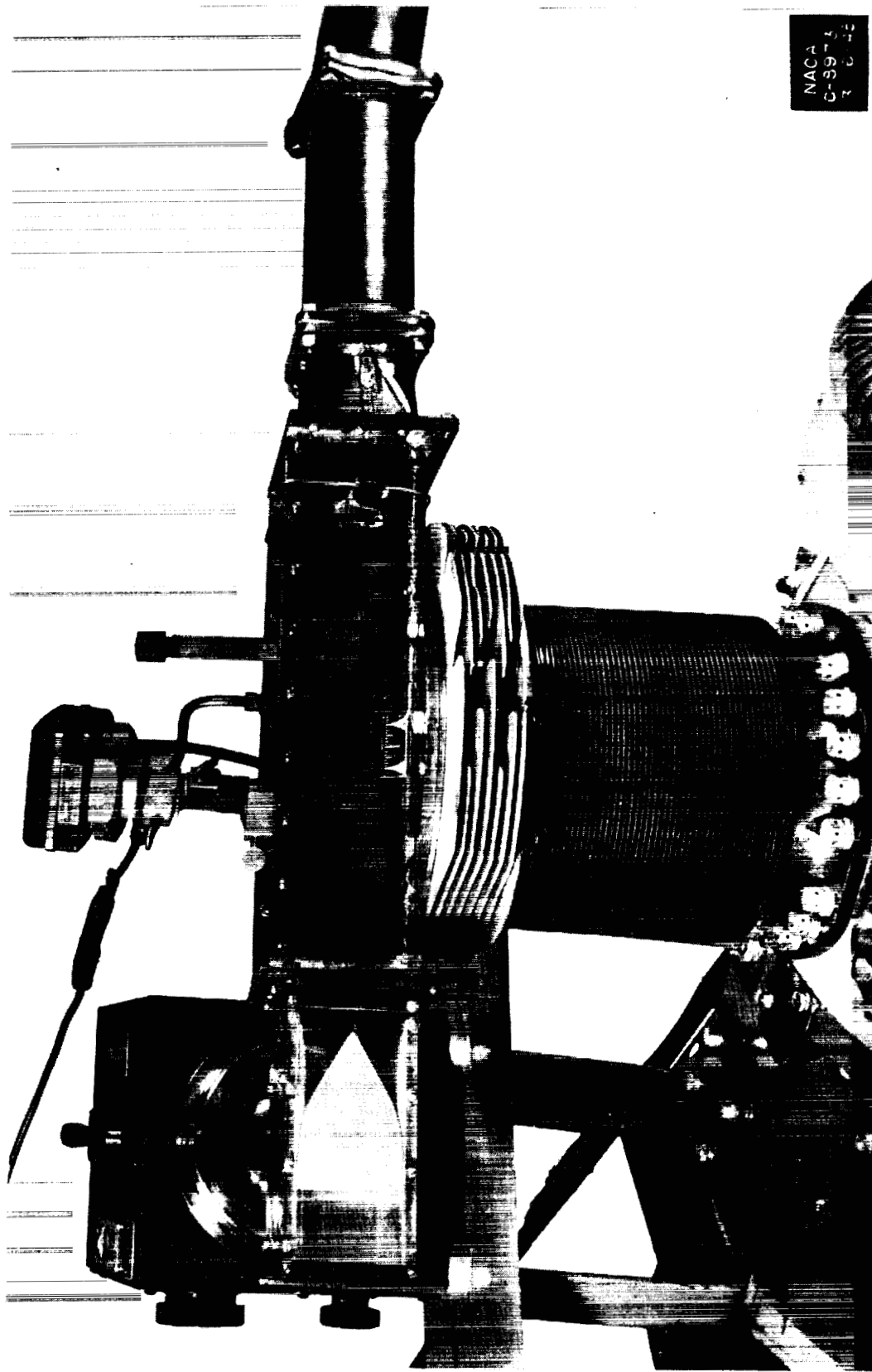


Figure 6. - Photographs of valves A, B, D, and E.



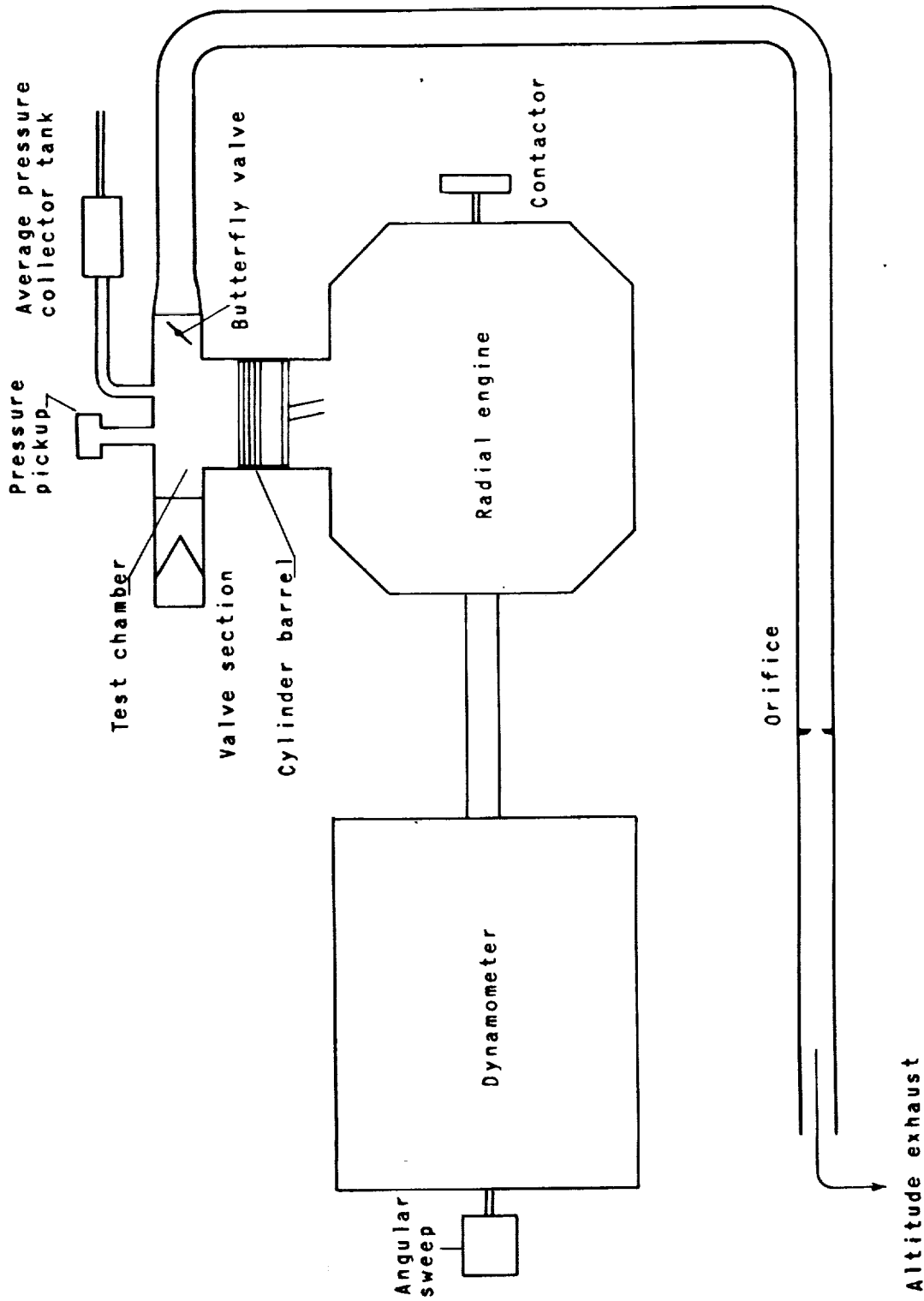
(a) Setup of equipment.

Figure 7. - Apparatus used in tests of air valves for intermittent-jet engines.



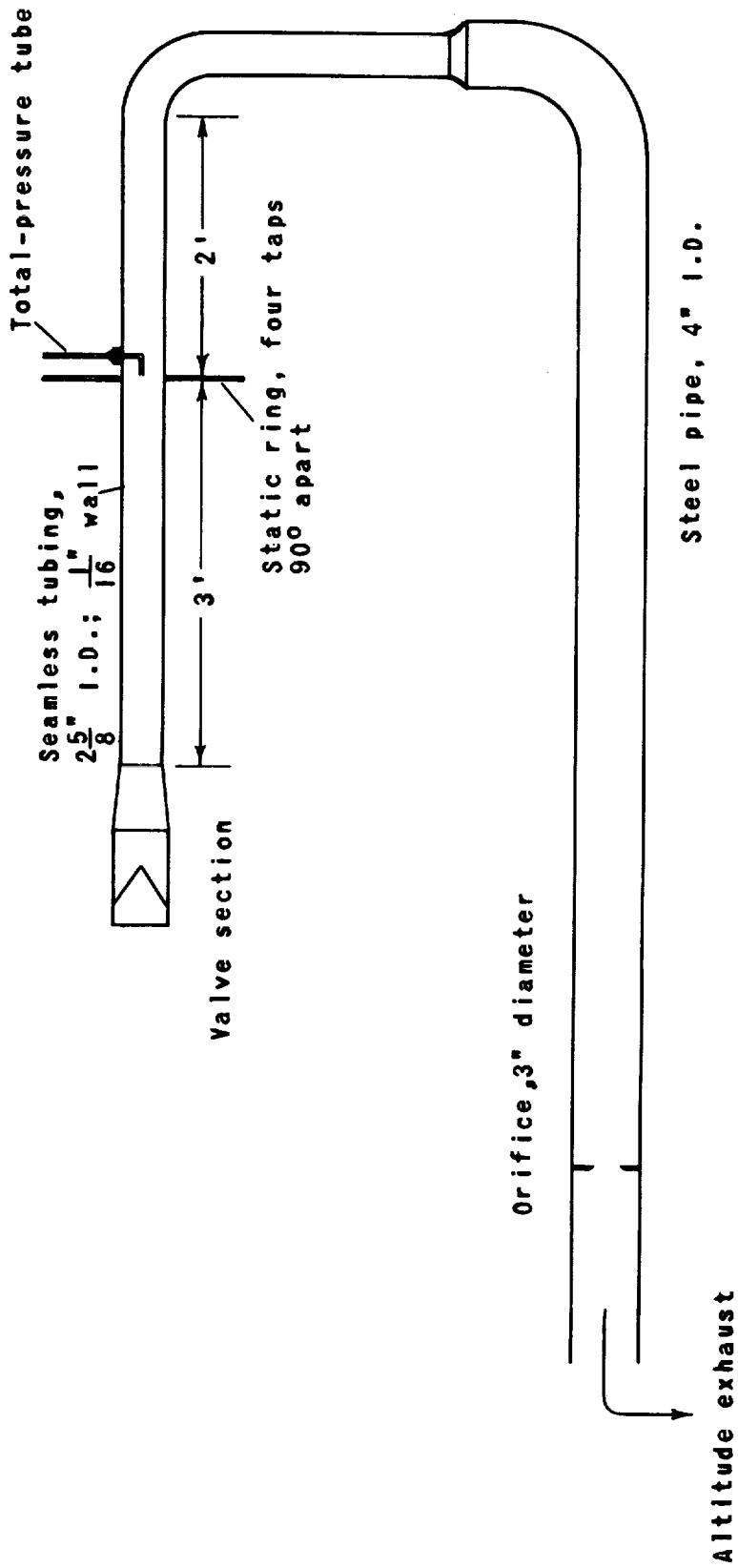
(b) Close-up of valve test section.

Figure 7. - Continued.



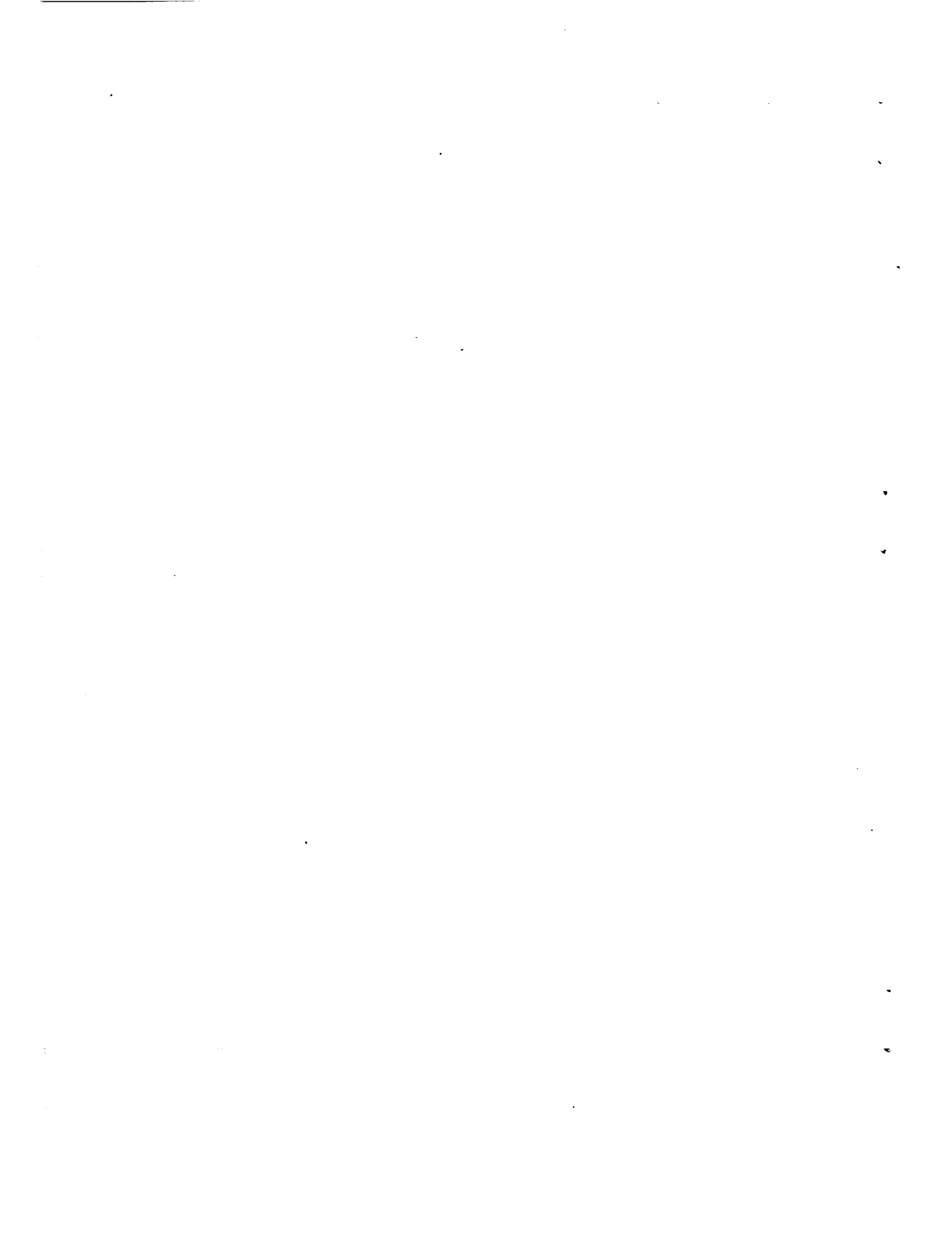
NATIONAL ADVISORY  
COMMITTEE FOR AERONAUTICS

(c) Schematic drawing of test apparatus.  
Figure 7. - Concluded.

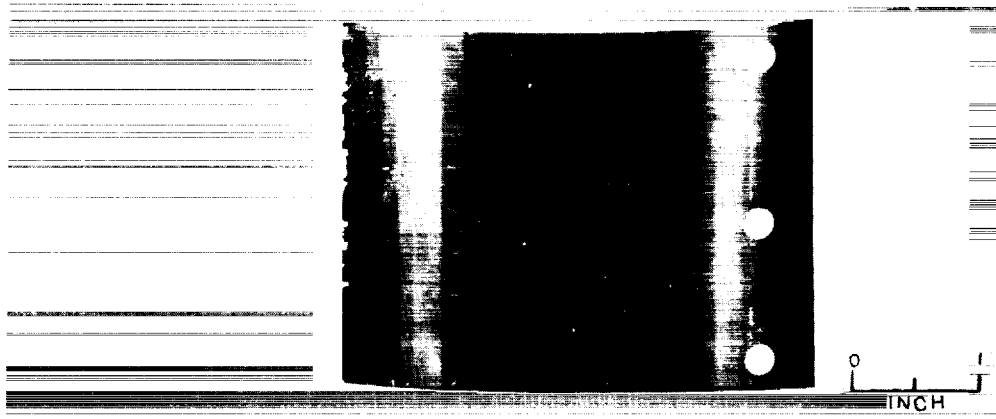


NATIONAL ADVISORY  
COMMITTEE FOR AERONAUTICS

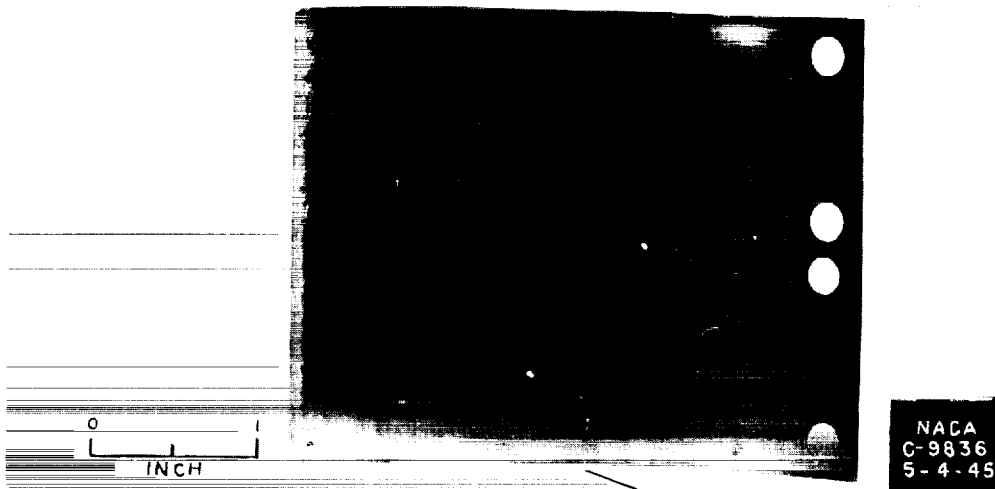
Figure 8. - Schematic drawing of steady-flow apparatus.







(a) Failure by fraying at valve tip or trailing edge.



Flex split

(b) Failure by flexing.

Figure 9. - Typical valve failures.



E-258

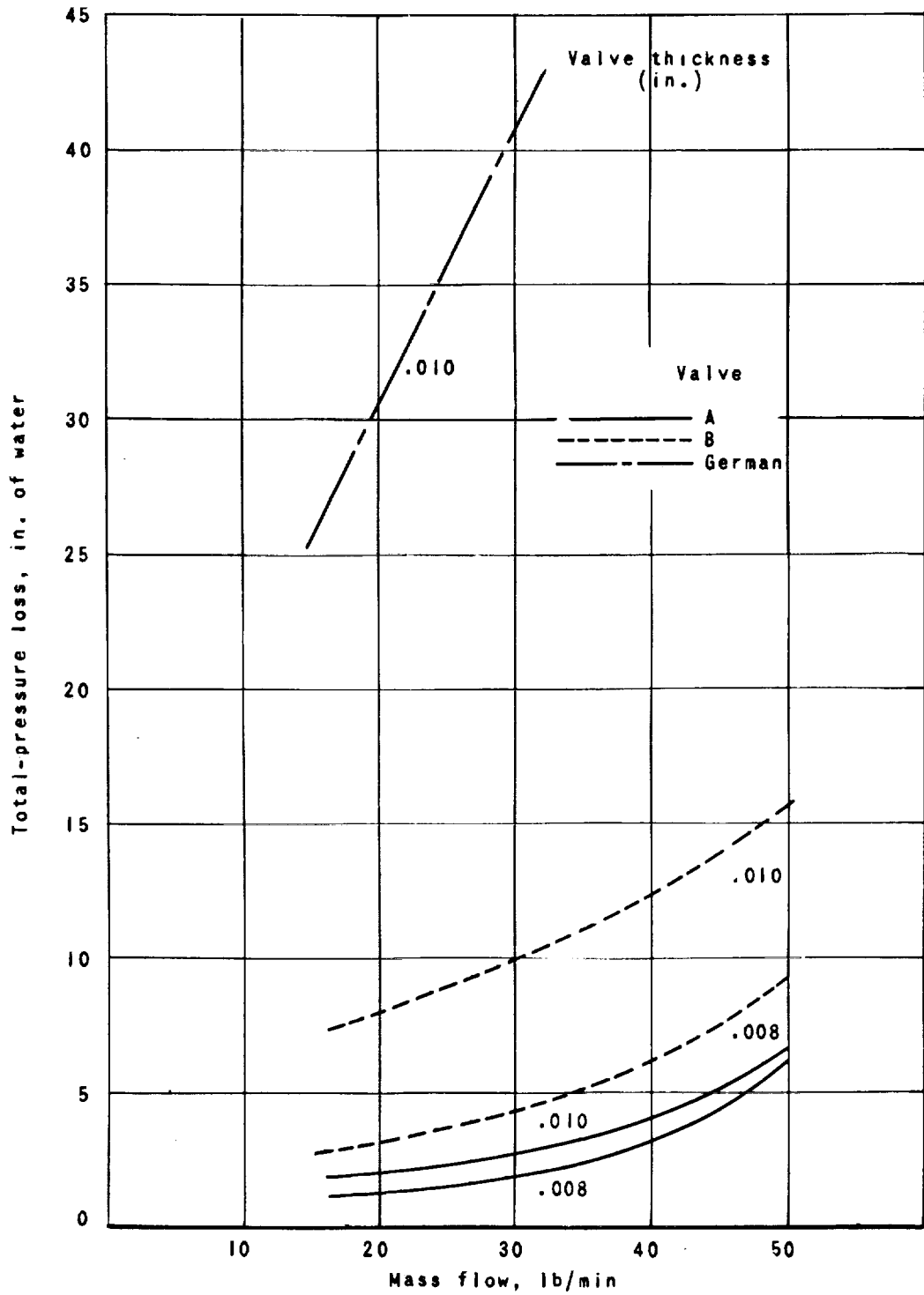
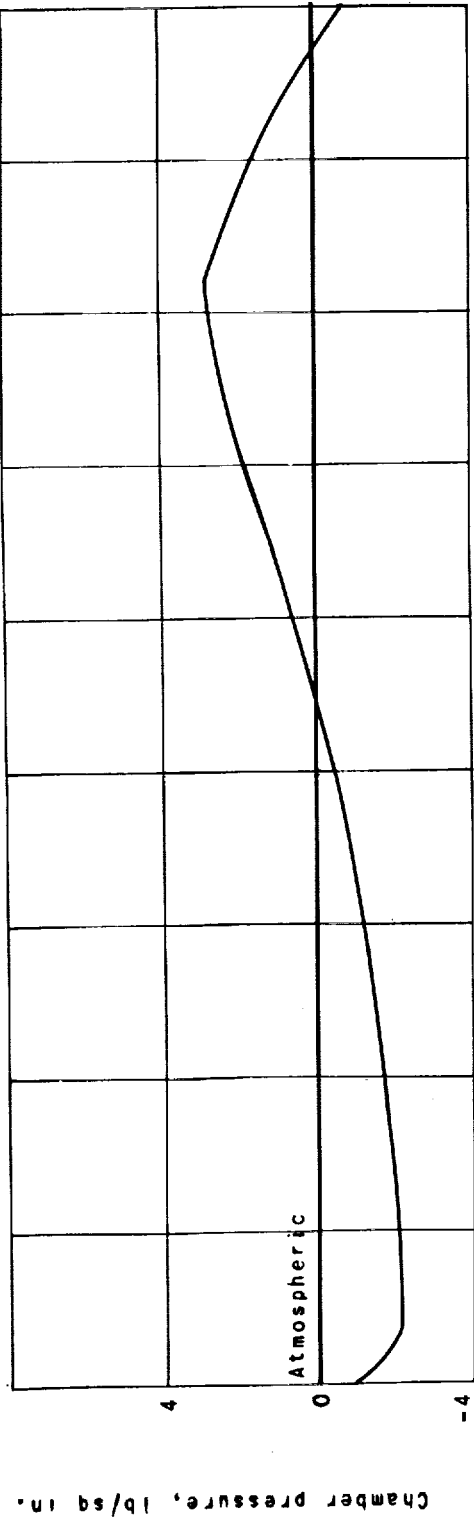


Figure 10. - Loss in total pressure at various mass flows for valves A, B, and the German type. Cross-sectional area of valve test sections, approximately 9 square inches.



NATIONAL ADVISORY  
COMMITTEE FOR AERONAUTICS

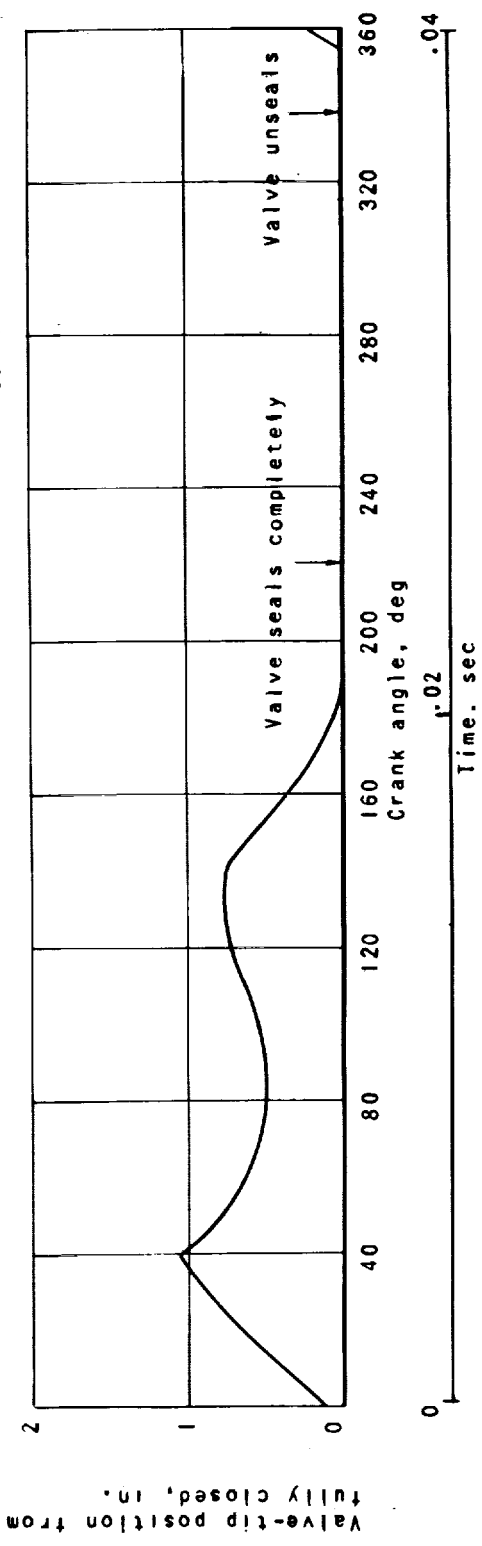


Figure 11. - Variation in chamber pressure and valve-tip position with engine crank angle or time for valve C at 25 cycles per second.